

ORIGINAL ARTICLE

Ergonomic Design and Evaluation of an Electric Nail Removal Device

MEHRDAD HELMI-KOHNE SHAHRI¹, ZEINAB KAZEMI², REZA FAZLI³, MEHRAN POURHOSSEIN³,
ADEL MAZLOUMI^{3*}

¹ Department of Occupational Health Engineering, School of Public Health, Shahid Beheshti University of Medical Sciences, Tehran, Iran

² Department of Ergonomics, School of Public Health, Iran University of Medical Sciences, Tehran, Iran

^{3*} Department of Occupational Health Engineering, School of Public Health, Tehran University of Medical Sciences, Tehran, Iran

Received July 02, 2021; Revised October 17, 2021; Accepted October 18, 2021

This paper is available on-line at <http://ijoh.tums.ac.ir>

ABSTRACT

Nowadays, musculoskeletal disorders resulting from working with improper hand tools have been known as one of the major concerns in various industries. In the current study, an ergonomic nail removal device was proposed to evaluate the intervention for nail removal activity in the woodworking and carpentry industry. Eleven male workers, who were actively involved in nail removing activity, were asked to perform nailing activity by removing nails driven into the bottom and top of the door as the base points for painting the doors using both the nail removal device and the traditional plier. The Rapid Entire Body Assessment (REBA) and Strain Index (SI) techniques were used to characterize the level of risk. Moreover, nailing task duration and task repetition were measured as important criteria in manual works. According to the SI and REBA risk indices, the final scores for the designed device were estimated at 2 (low-risk level) and 1.5 (safe), respectively, while these values for the traditional pliers were 12 (high-risk level) and 15 (dangerous). Moreover, using the designed electric nail removal device led to a reduction in the repetition and duration of the task. Overall, the application of the proposed device in the nail removal tasks has shown risk indices below the critical thresholds in terms of correcting work posture and reducing strains imposed on workers' upper limbs.

KEYWORDS: Ergonomics, Nail Removal Device, REBA, Strain Index, Musculoskeletal Disorders

INTRODUCTION

Hand tools are frequently used by workers in a vast number of industrial occupations [1-3]. Working with hand tools has been linked with several musculoskeletal risks [3, 4], especially upper extremity cumulative trauma disorders (CTDs) in

upper limbs [5-7]. CTDs, caused by repetitive exposure to a type of physical risk factor [8], have been considerably grown over the past few decades [5, 6, 9]. These injuries develop over time due to a variety of micro-traumas [8] and were associated with work activities in a wide range of tasks [7].

Corresponding author: Adel Mazloumi

E-mail: amazlomi@tums.ac.ir

According to the literature, about half of the top 10 industries reporting musculoskeletal disorders including assemblers, construction workers, supervisors in sales, carpenters, and cashiers, are at risk of developing work-related musculoskeletal disorders (WMSDs) in the upper extremity through hand-stressing work or the use of improper hand tools [10]. The US Department of Labor, Bureau of Labor Statistics, (2013) showed that the incidence rate of occupational injuries related to upper extremities (shoulder, arm, wrist, and hand) was 32.5%. Furthermore, 4.6% of all injuries and illnesses have been attributed to hand tools [11].

Previous studies have identified awkward postures (i.e. flexion and extension, radial, and ulnar deviations), excessive muscular force, high rates of manual repetition, and vibration as the main risk factors for hand tool-related disorders [7, 12, 13]. For instance, a systematic review by UK Industrial Injuries Advisory Council reported that sustained flexion and extension and also repetitive hand movements accompanied by forceful grip increase, approximately 2 times the risk of carpal tunnel syndrome [14, 15]. Working with hand tools involves one or more of the aforementioned factors. Therefore, it can increase fatigue and discomfort, particularly if the task requires sustained weight supporting of the tool [16]. This may be due to the high stresses imposed on the hand structures [17]. Hence, many ergonomic interventions have been proposed to reduce the adverse consequences so far. In this sense, hand tool design and redesign have been introduced as a crucial factor in the reduction of hand and wrist discomfort and injuries [7].

In the past, hand tools were designed based on their functions, mostly as mechanical non-powered tools. However, recently, particular attention has been paid to comfortable and preferably powered hand tools. The use of hand tools may lead to feelings of discomfort over bouts of work [18], which consequently can reduce efficiency and workers' job satisfaction [16]. The work efficiency and productivity can be improved by enhancing the quality and

usability of hand tools and considering ergonomic principles in the product design [19-22]. Hand tools ergonomic design can also decrease biomechanical strain and the rate of injuries and the risk factors for CTDs [21-23]. Moreover, comfort has attracted considerable attention from hand tools manufacturers as a key factor in selling products [21].

Due to the nature of carpenters' jobs in Iran, they have to frequently remove nails. Removing nails is amongst the most stressful and physically demanding activities. Using the traditional tools for removing nails (such as pliers), imposes a high level of strain to the user, especially when done repeatedly [24]. Therefore, the main purposes of the present paper were: (1) to develop an electric nail removal device to reduce the risks of manual procedures over the nail removal activity and (2) to evaluate the designed device from an ergonomics point of view.

METHODS AND MATERIALS

Study population and task description:

Eleven male workers were selected for ergonomic investigations of the target nailing task. Participants' mean \pm SD age, weight, and stature were 29 ± 2.9 years, 73.6 ± 10.3 kg, and 177 ± 4.5 cm, respectively. All participants had no known musculoskeletal injuries or disorders that may affect their ability to perform the nailing task. Informed consent forms were collected before the experiment.

In the current study, the nail removal task in the woodworking and carpentry industry was selected. In this industry, several 12 cm nails were driven into the bottom and top of the door as the base points for painting the doors. In the packing section, the nails were removed after drying the paintings, using pliers (see Figure 1). This repetitive manual task requires forceful exertions and simultaneously awkward posture, and using the conventional plier had meaningful risks. Figure 2 represents the activity of nail removal via pliers.



Figure 1. The plier used in this study.

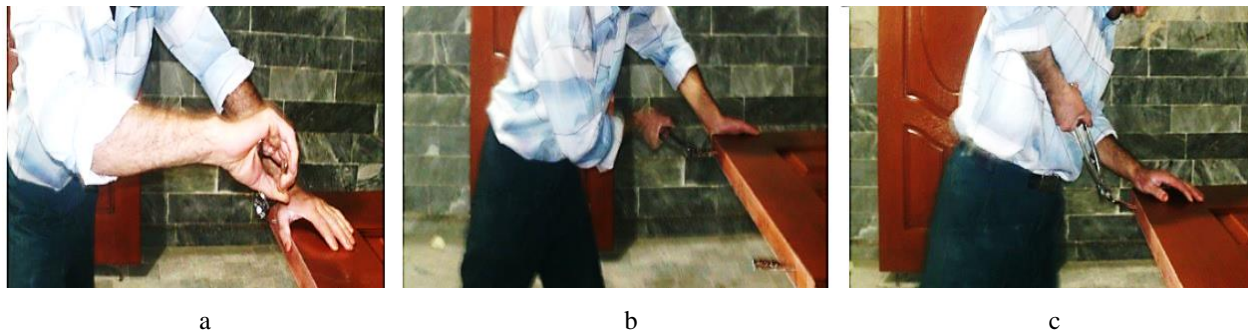

Figure 2. Worker hand posture during manual nail removing using pliers: a) start of nailing activity, b) middle phase, c) last phase.

Design of electric nail removal device:

In the first step, the literature was reviewed for the existing electric nail removal devices. Although several attempts have been done to redesign the available traditional pliers [25, 26], no electric tools were found. In the present study, the electric nail removal device was designed to be used in the door manufacturing industry. The principal concept for this design was to reduce awkward postures and exertion force in nail removal activities and also to generate significant modifications in the work procedures. The primary design of the electric nail removal device was done using SolidWorks 2013 x64 Edition. The schematic of the electric nail removal device was presented in Figure 3. Following the primary design, the first prototype was made in the welding section of the study factory. The constructed electric nail removal device consisted of 7 parts (Figure 3-c): hook (for gripping the nail) (No. 1), bearings (for keeping

the hook stable) (No. 2), screw (force transmission to the hook) (No. 3), nut (changing the rotational force to tensile force with screw help) (No. 4), chuck (transmission of rotational force to the screw) (No. 5), the body (placed on the piece that the nail removed from) (No. 6), and the shield (to prevent hitting the worker's hand with the spinning screw) (No. 7).

In this system, the rotational force of the drill transmits to the screw by connecting to the chuck. As an exploratory work, this rotational force then was converted to tensile force in the nut and bearings. The tensile force then was transferred to the nail by means of the hook. On the other hand, the reaction force exerted to the nail was applied to the device by the system body, which facilitates the nail removal. Figure 4 represents workers while removing nails with the ergonomically designed device.

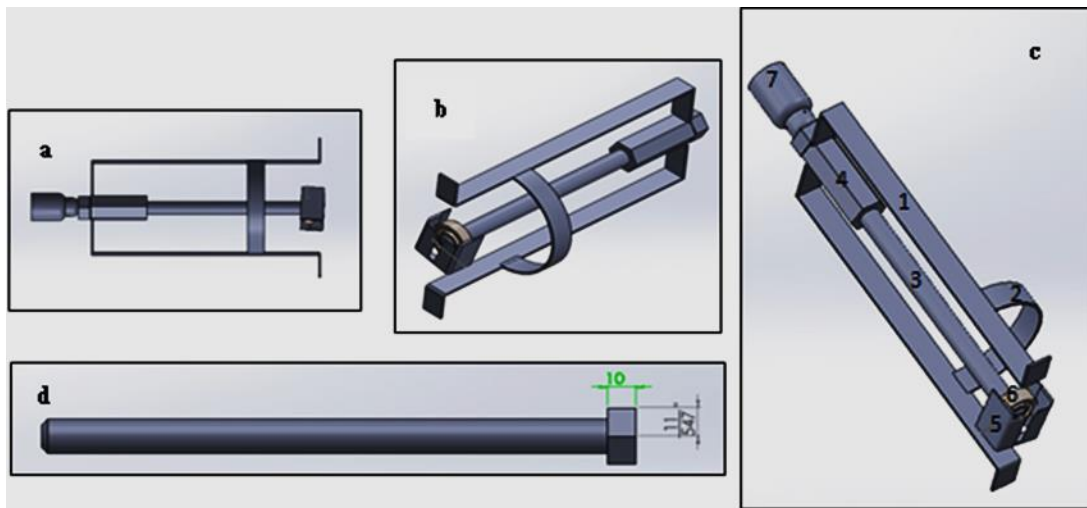

Figure 3. The primary design of electric nail removal device, using SolidWorks 2013 x64 Edition, a) top view, b and c) oblique view, d) side view c: 1) hook, 2) bearings, 3) screw, 4) nut, 5) chuck, 6) the body, and 7) the shield.

Study procedure and data collection tools:

In the present research, first, a detailed analysis of the involved tasks and subtasks was done. Subsequently, the high-risk working postures involved in nail removal tasks were identified in the woodworking and carpentry industry. The total cycle time for nail removal work was estimated at approximately 2 minutes, of which 45 seconds were belonged to nail removal activity. The “number of repetitive motions done by the worker to remove the nail” and “mean

duration of one nailing activity (sec)” were measured as the main criteria for assessment of the manual task. These two variables were compared while using both pliers and ergonomics nail removal devices. Moreover, Strain Index (SI) and Rapid Entire Body Assessment (REBA) techniques were used in order to the effectiveness of the designed device. In this sense, photography/videotaping of the target tasks were done from the sagittal plane for further investigation and for extracting the required data.



Figure 4. The ergonomically designed nail removal device.

Strain Index (SI):

Strain Index was developed by Moore and Garg (1995) to identify jobs prone to distal upper extremities disorders [27]. Strain Index uses six factors that multiply the weighted scores of these variables gives a single score of Strain Index [28-30]:

1. *Intensity of Exertion (IEM)* is a qualitative measure of the percent maximum voluntary contraction that a task requires and relies on workers' facial expression changes and other biomechanical indicators of exertion intensity.
2. *Duration of Effort (DEM)* is the duration of the exertion and reflects the physiological and biomechanical stress related to how long an exertion is maintained.
3. *Efforts per Minute (EMM)* is the frequency of exertions per minute.
4. *Hand/wrist posture (HPM)* shows the anatomical posture of the hand.
5. *Speed of Work (SWM)* estimates the perceived pace of the task and accounts for the additional stresses associated with dynamic work.

6. *Duration of Task (DDM)* is a measure of how much of the workday is allocated to performing that task.

The risk classification of the Strain Index is a three-level scale as <3 (safe), 3-6.9 (caution), ≥ 7 (hazardous) [31]. Work activities were observed and videotaped to determine the required information. In this sense, the duration of the work cycle and exertional times were measured with a stopwatch.

Rapid Entire Body Assessment (REBA):

The study used the Rapid Entire Body Assessment technique, developed by Hignett and McAtamney (2000) [32], as a rapid and simple observational postural analysis instrument for the assessment of whole-body activities, providing a musculoskeletal risk action level [33]. The REBA technique evaluates factors, including body posture, forceful exertions, type of action, repetition, and coupling [34]. The REBA action level has been indicated in Table 1. According to working images, the most physically stressful body postures were selected for REBA assessment.

Table 1. The REBA action level.

Action level	REBA score	Risk level	Action
0	1	Negligible	Corrective action including further assessment is not necessary
1	2-3	Low	Corrective action including further assessment may be necessary
2	4-7	Medium	Corrective action including further assessment is necessary
3	8-10	High	Corrective action including further assessment is necessary soon
4	11-15	Very high	Corrective action including further assessment is necessary now

RESULTS

Final scores of REBA and SI were calculated while using traditional pliers as well as the designed electric nail removal device (Table 2). As it is depicted in Table 2, the final REBA and SI scores, number of repetitive motions done by workers to remove the nail, and mean duration of one nailing activity were significantly improved while using the designed device. The mean time to complete one nail removal activity was also dropped by 10 seconds. Furthermore, the repetitive motions required for one nail removal activity were reduced from 15 times per nailing activity while using the plier to zero (i.e. requiring no repetitive motion) while using the electric device (Table 2). Overall, the final scores for nail removal activity using the ergonomically designed nailing device were presumed "safe" ($SI < 3$) while it was rated as "hazardous" for the traditional method ($SI \geq 7$).

Non-parametric paired Wilcoxon signed-rank test was used to assess differences in SI sub-items while using the traditional plier and the designed electric nail removal device. According to the results, all risk factors assessed by Strain Index have obtained a better score after using the electric nail removal device ($P < 0.05$) (Table 3).

Further, the final SI score was reduced by approximately 90 percent. Table 4 represents findings related to the posture assessment. In this sense, the value of all variables was significantly reduced so that the final score of 12, (i.e. corrective action including further assessment is necessary now) was reduced to 2 (i.e. corrective action including further assessment may be necessary) ($p\text{-value} < 0.0001$).

Table 2. Comparing the results of the posture assessment and ergonomics criteria before and after using the designed nail removal device.

Variables	Result of assessment (using plier)	Consideration	Result of assessment (using electric nail removal design)	Consideration
REBA score	12	Corrective action including further assessment is necessary now	2	Corrective action including further assessment may be necessary
SI score	15	hazardous	1.5	safe
Nailing task duration	14 sec	The mean time is about 14 seconds for traditional nailing.	4 sec	The mean time is about 4 seconds for the designed nailing device.
Number of repetitive motion	15 times	For every nail, on average, 15 repetitive cyclic motions were done.	0 times	There is no repetitive motion.

Table 3. Comparison of results of strain index assessments using traditional pliers and the designed electric nail removal device (Wilcoxon Signed-Rank Test).

Risk factor	Final score		P-value
	Before intervention	After intervention	
Intensity of Exertion	9 (substantial effort; Changes expression)	3 (noticeable or definite effort)	<0.001*
Duration of Exertion (% of Cycle)	1.5 (35% cycle)	1 (10-29% cycle)	0.028*
Efforts Per Minute	0.5 (4 efforts per minute)	1 (2 efforts per minute)	0.012*
Hand/Wrist Posture	2 (bad: marked deviation)	1 (good: near neutral)	0.002*
Speed of Work	1.5 (fast: rushed, but able to keep up)	1 (fair: normal speed of motion)	0.015*
Duration of Task Per Day (hours)	0.75 (2 < 4)	0.5 (1 < 2)	0.022*
Total score	15.18	1.5	<0.001*

Table 4. Comparison of REBA posture assessment outputs using traditional pliers and the designed electric nail removal device (Wilcoxon Signed-Rank Test).

Parameters	Final score (Median)		P-value
	Before intervention	After intervention	
<i>Body parts</i>			
Trunk	4	2	0.001*
Neck	2	1	0.014*
Leg	2	1	0.005*
Upper arm	3	1	0.000*
Lower arm	2	1	0.002*
Wrist	3	1	<0.001*
Load/Force	2	0	0.001*
Coupling	2	0	0.001*
Activity score	2	1	0.020*
Total score	12	2	0.000*

DISCUSSION

The present study was conducted to develop an electric nail removal device for nail removal activities and also to evaluate the designed device by comparing it with the traditional method (pliers). The rise of work-related musculoskeletal disorders of the upper limbs in industries that widely use hand tools was spurred great interest amongst users, manufacturers, and researchers [35]. The main idea was to eliminate stressful body postures and muscle exertions. In this regard, it should be noted that pliers were not originally designed for nail removal activities, showing the mismatch of the tool and the

task, which was the main risk factor for musculoskeletal disorders [24, 26]. Thus, the workers had to match themselves while working with this tool, resulting in awkward and harmful postures and may adversely affect the task performance [36-38]. Nail removal activities using pliers may cause a condition known as "hammer elbow", a condition involving inflammation and pain of the elbow [39], showing the necessity for the development of an alternative device.

Based on the results of SI and REBA ergonomic risk measures in this study, it was observed that working posture reached an acceptable level after

using the designed device. In this sense, the posture of different body regions including the trunk, neck, leg, upper and lower arm, and wrist were significantly improved and the frequency (efforts per minute) was decreased, remarkably. On the other hand, by shortening the time required for nailing activity, the risk of musculoskeletal disorders would be reduced in addition to the increase in work efficiency. This can be explained by the shorter time required for each operation.

Overall, replacing the electric nail removal device, and changing the manually demanding high-risk nailing activities to the mechanically effective ones had main positive effects, including (1) improvement of workers' health and prevention of musculoskeletal disorders and (2) increase of productivity and efficiency and a considerable reduction in costs. The latter would be obtained by an increase in work speed, lack of damage to the nails and the possibility to reuse it (due to direct pulling of the nail without bending it), and also lack of damage to the piece of the nails pulled from it. The new nail removal ergonomic designed device was found to be applicable and acceptable for the target workers. For the sake of comparison, no similar study was found. However, replacing the traditional hand tools with corresponding electrical devices as well as the redesign of available traditional hand tools have shown promising results in previous studies. For instance, a comparison of pneumatic and electrical pistol grip hand tools by Potvin et al. (2004) showed the reduction of the demands on the forearms during horizontal drilling while using the electrical pistol grip tool [40]. Bent-handled needle-nose pliers were designed considering the ergonomics principles by Haque and Khan (2010) and the results confirmed the reduction of discomfort [25].

The designed device had some new features which can be investigated for modifications in future studies, consisting of vibration and safety issues. Furthermore, in this study, no attempt was made to measure the effects of the new nail removal device on the workers' performance. Further field trials were recommended to test the efficiency under real production conditions. Since the electric nail removal device was heavier as compared to the traditional plier, the effect of this factor on postural load was also recommended to be

investigated for a more comprehensive evaluation of the device.

CONCLUSION

A new electric device for nail removal activities was proposed in the present research and its impact on postural load imposed to upper extremities was objectively assessed. The main aim was to reduce the stress imposed on the hand and wrist while performing nail removal tasks via the traditional tool. Overall, the newly designed device provided smooth movements, instead of high muscular effort. Moreover, the new device omitted unnecessary forceful exertions, which were analyzed by Strain Index. A significant reduction was observed in the overall score of the Strain Index since the highest score belonged to the intensity of exertion in this assessment tool. Repetitive unnatural postures of the wrist and supination/pronation of the forearm as required while using pliers were also decreased.

ACKNOWLEDGEMENT

The authors gratefully acknowledge the participants for their kind cooperation.

CONFLICT OF INTEREST

The authors declare that they have no competing interest.

REFERENCES

1. Dianat I, Haslegrave CM, Stedmon AW. Using pliers in assembly work: Short and long task duration effects of gloves on hand performance capabilities and subjective assessments of discomfort and ease of tool manipulation. *Appl Ergon.* 2012; 43(2): 413-423.
2. Kong YK, Lowe BD, Lee SJ, Krieg EF. Evaluation of handle design characteristics in a maximum screwdriving torque task. *Ergonomics.* 2007; 50(9): 1404-1418.
3. Motamedzade M, Choobineh A, Mououdi MA, Arghami S. Ergonomic design of carpet weaving hand tools. *Int J Ind Ergon.* 2007; 37(7): 581-587.
4. Dianat I, Nedaei M, Nezami MAM. The effects of tool handle shape on hand performance, usability and discomfort using masons' trowels. *Int J Ind Ergon.* 2015; 45: 13-20.
5. Aghazadeh F, Mital A. Injuries due to handtools: Results of a questionnaire. *Appl Ergon.* 1987; 18(4): 273-278.
6. Punnett L, Wegman DH. Work-related musculoskeletal disorders: the epidemiologic evidence and the debate. *J Electromyogr Kinesiol.* 2004; 14(1): 13-23.
7. Li KW. Ergonomic design and evaluation of wire-tying hand tools. *Int J Ind Ergon.* 2002; 30(3): 149-161.
8. Cázares-Manríquez MA, Camargo-Wilson C, Vardasca R, García-Alcaraz JL, Olguin-Tiznado JE, López-Barreras JA, et al. Quantitative Models for Prediction of Cumulative Trauma Disorders Applied to the Maquiladora Industry. *Int J Environ Res Public Health.* 2021; 18(7): 3830.
9. Houvet P, Obert L. Upper limb cumulative trauma disorders for the orthopaedic surgeon. *Orthop Traumatol Surg Res.* 2013; 99(1): S104-S14.
10. Barr AE, Barbe MF, Clark BD. Work-related musculoskeletal disorders of the hand and wrist: epidemiology, pathophysiology, and sensorimotor changes. *J Orthop Sports Phys Ther.* 2004; 34(10): 610-627.
11. Bureau of Labor Statistics. Nonfatal occupational injuries and illnesses requiring days away from work 2013. Available from: www.bls.gov/news.release/pdf/osh2.pdf.
12. Kazemi Z, Mazloumi A, Arjmand N, Keihani A, Karimi Z, Ghasemi MS, Kordi R. A Comprehensive Evaluation of Spine Kinematics, Kinetics, and Trunk Muscle Activities During Fatigue-Induced Repetitive Lifting. *Hum Factors.* 2021.
13. Vahedi Z, Mazloumi A, Sharifnezhad A, Kazemi Z, Garosi E. Head forward flexion, lateral bending and viewing distance while using a smartphone: A comparison between sitting and standing postures. *Work.* 2020; 67(4): 1-10.
14. Barcenilla A, March LM, Chen JS, Sambrook PN. Carpal tunnel syndrome and its relationship to occupation: a meta-analysis. *Rheumatology.* 2012; 51(2): 250-261.
15. Palmer K, Harris E, Coggon D. Carpal tunnel syndrome and its relation to occupation: a systematic literature review. *Occup Med.* 2006; 57(1): 57-66.
16. Fellows G, Freivalds A. Ergonomics evaluation of a foam rubber grip for tool handles. *Appl Ergon.* 1991; 22(4): 225-230.
17. Aldien Y, Welcome D, Rakheja S, Dong R, Boileau P-E. Contact pressure distribution at hand-handle interface: role of hand forces and handle size. *Int J Ind Ergon.* 2005; 35(3): 267-286.
18. Kuijt-Evers LF, Groenesteijn L, de Looze MP, Vink P. Identifying factors of comfort in using hand tools. *Appl Ergon.* 2004; 35(5): 453-458.
19. Harih G, Dolšak B. Tool-handle design based on a digital human hand model. *Int J Ind Ergon.* 2013; 43(4): 288-295.
20. Hogberg D, Backstrand G, Lamkull D, Hanson L, Ortengren R. Industrial customisation of digital human modelling tools. *Int J Serv Oper Inform.* 2008; 3(1): 53-70.
21. Kuijt-Evers LFM, Bosch T, Huysmans MA, De Looze MP, Vink P. Association between objective and subjective measurements of comfort and discomfort in hand tools. *Appl Ergon.* 2007; 38(5): 643-654.
22. Päivinen M, Heinimaa T. The usability and ergonomics of axes. *Appl Ergon.* 2009; 40(4): 790-796.

23. Li KW. Ergonomic evaluation of a fixture used for power driven wire-tying hand tools. *Int J Ind Ergon.* 2003; 32(2): 71-79.
24. Kim BB. Effect of ergonomic design changes in hand tools on physiological cost and subjective ratings. *Int J Occup Saf Ergon.* 2012; 18(2): 267-277.
25. Haque S, Khan AA. Ergonomic design and evaluation of pliers. *Work.* 2010; 37(2): 135-143.
26. You H, Kumar A, Young R, Veluswamy P, Malzahn DE. An ergonomic evaluation of manual Cleco plier designs: Effects of rubber grip, spring recoil, and worksurface angle. *Appl Ergon.* 2005; 36(5): 575-583.
27. Steven Moore J, Garg A. The strain index: a proposed method to analyze jobs for risk of distal upper extremity disorders. *American Indus Hygiene Association* 1995; 56(5): 443-458.
28. Drinkaus P, Bloswick DS, Seseck R, Mann C, Bernard T. Job level risk assessment using task level strain index scores: a pilot study. *Int J Occup Saf Ergon.* 2005; 11(2): 141-152.
29. Drinkaus P, Seseck R, Bloswick D, Bernard T, Walton B, Joseph B, Reeve G, Counts JH. Comparison of ergonomic risk assessment outputs from Rapid Upper Limb Assessment and the Strain Index for tasks in automotive assembly plants. *Work.* 2002; 21(2): 165-172.
30. Rosecrance J, Paulsen R, Murgia L. Risk assessment of cheese processing tasks using the Strain Index and OCRA Checklist. *Int J Ind Ergon.* 2017; 61: 142-148.
31. Paulsen R, Gallu T, Gilkey D, Reiser R, Murgia L, Rosecrance J. The inter-rater reliability of Strain Index and OCRA Checklist task assessments in cheese processing. *Appl Ergon.* 2015; 51: 199-204.
32. Hignett S, McAtamney L. Rapid entire body assessment (REBA). *Appl Ergon.* 2000; 31(2): 201-205.
33. Joshi EG, Lal H. REBA Technique on Small Scale Casting Industry. *Int J Emerg Technol Learn.* 2014; 5(2): 61.
34. Kamble R, Kulkarni V. Productivity improvement at assembly station using work study techniques. *Int J Eng Res Technol.* 2014; 3(9): 480-487.
35. Aptel M, Claudon L, Marsot J. Integration of ergonomics into hand tool design: principle and presentation of an example. *Int J Occup Saf Ergon.* 2002; 8(1): 107-115.
36. Berguer R, Hreljac A. The relationship between hand size and difficulty using surgical instruments: a survey of 726 laparoscopic surgeons. *Surg Endosc other Interv Tech.* 2004; 18(3): 508-512.
37. González A, Barrios-Muriel J, Romero-Sánchez F, Salgado D, Alonso F. Ergonomic assessment of a new hand tool design for laparoscopic surgery based on surgeons' muscular activity. *Appl Ergon.* 2020; 88: 103161.
38. Yusoff ISM, Tamrin SBM, Aini M, Ng YG, Ippei M. Oil Palm Workers: Designing Ergonomics Harvesting Tool Using User Centered Design Approach to Reducing Awkward Body Posture by Catia Simulation. *Iran J Public Health.* 2014; 43(3): 72-80.
39. Caron B, Demicco A, Elliott M, Turner D, Suh D. *Design of a nail removal device.* Department of Mechanical, Industrial, and Manufacturing Engineering. Northeastern University Boston, USA, 2007.
40. Potvin JR, Agnew MJ, Ver Woert C. An ergonomic comparison of pneumatic and electrical pistol grip hand tools. *Int J Ind Ergon.* 2004; 34(6): 467-478.
23. Li KW. Ergonomic evaluation of a fixture used for power driven wire-tying hand tools. *Int J Ind Ergon* 2003; 32(2): 71-9.
24. Kim BB. Effect of ergonomic design changes in hand tools on physiological cost and subjective ratings. *Int J Occup Saf Ergon* 2012; 18(2): 267-77.
25. Haque S, Khan AA. Ergonomic design and evaluation of pliers. *Work* 2010; 37(2): 135-43.
26. You H, Kumar A, Young R, Veluswamy P, Malzahn DE. An ergonomic evaluation of manual Cleco plier designs: Effects of rubber grip, spring recoil, and worksurface angle. *Appl Ergon* 2005; 36(5): 575-83.
27. Steven Moore J, Garg A. The strain index: a proposed method to analyze jobs for risk of distal upper extremity disorders. *American Industrial Hygiene Association* 1995; 56(5): 443-58.
28. Drinkaus P, Bloswick DS, Seseck R, Mann C, Bernard T. Job level risk assessment using task level strain index scores: a pilot study. *Int J Occup Saf Ergon* 2005; 11(2): 141-52.
29. Drinkaus P, Seseck R, Bloswick D, Bernard T, Walton B, Joseph B, et al. Comparison of ergonomic risk assessment outputs from Rapid

- Upper Limb Assessment and the Strain Index for tasks in automotive assembly plants. *Work* 2002; 21(2): 165-72.
30. Rosecrance J, Paulsen R, Murgia L. Risk assessment of cheese processing tasks using the Strain Index and OCRA Checklist. *Int J Ind Ergon* 2017; 61: 142-8.
 31. Paulsen R, Gallu T, Gilkey D, Reiser R, Murgia L, Rosecrance J. The inter-rater reliability of Strain Index and OCRA Checklist task assessments in cheese processing. *Appl Ergon* 2015; 51: 199-204.
 32. Hignett S, McAtamney L. Rapid entire body assessment (REBA). *Appl Ergon* 2000; 31(2): 201-5.
 33. Joshi EG, Lal H. REBA Technique on Small Scale Casting Industry. *Int J Emerg Technol Learn* 2014; 5(2): 61.
 34. Kamble R, Kulkarni V. Productivity improvement at assembly station using work study techniques. *Int J Eng Res Technol* 2014; 3(9): 480-7.
 35. Aptel M, Claudon L, Marsot J. Integration of ergonomics into hand tool design: principle and presentation of an example. *Int J Occup Saf Ergon* 2002; 8(1): 107-15.
 36. Berguer R, Hreljac A. The relationship between hand size and difficulty using surgical instruments: a survey of 726 laparoscopic surgeons. *Surg endosc other interv tech* 2004; 18(3): 508-12.
 37. González A, Barrios-Muriel J, Romero-Sánchez F, Salgado D, Alonso F. Ergonomic assessment of a new hand tool design for laparoscopic surgery based on surgeons' muscular activity. *Appl Ergon* 2020; 88: 103161.
 38. Yusoff ISM, Tamrin SBM, Aini M, Ng YG, Ippei M. Oil Palm Workers: Designing Ergonomics Harvesting Tool Using User Centered Design Approach to Reducing Awkward Body Posture by Catia Simulation. *Iran J Public Health* 2014; 43(3): 72-80.
 39. Caron B, Demicco A, Elliott M, Turner D, Suh D. Design of a nail removal device. Northeastern University Boston. Department of Mechanical, Industrial, and Manufacturing Engineering. 2007.
 40. Potvin JR, Agnew MJ, Ver Woert C. An ergonomic comparison of pneumatic and electrical pistol grip hand tools. *Int J Ind Ergon* 2004; 34(6): 467-78.