

Evolving Essential Inherently Safer Design Assessment Principles Based Fuzzy Inherently Safer Design Index, Case Study for Acetic Acid Production Plant

HAMID SARKHEIL^{1*}, YOUSEF AZIMI¹, SHAHROKH RAHBARI², JAVAD TAVAKOLI², PAYAM SHAYAN FARD²

¹ Faculty Member of Department of Human Environment, College of Environment, Karaj, Iran;

² MSc Student in Chemical Engineering-HSE, Department of Human Environment, College of Environment, Karaj, Iran.

Received January 07, 2017; Revised January 29, 2017; Accepted February 21, 2017

This paper is available on-line at <http://ijoh.tums.ac.ir>

ABSTRACT

Inherently Safer Design (ISD) is served as an important and crucial step for Industrial Safety Management Systems. It is simpler, cheaper, and more efficient to eliminate and/or reduce inherent hazards. However, uncertainty, relativity, ambiguousness, and quality/quantity transformations disrupt the implementation of ISD. As advantages of fuzzy reasoning, naming problems can be resolved in order to have a justified and sophisticated decision making about Inherently Safer Design Assessment. Accordingly in this paper, ISD four principles: 1. Elimination/Substitution, 2. Minimization, 3. Moderation, and 4. Simplification enters the Fuzzy Mamdani system: Fuzzy ISD Index (FISDI) to accomplish Fuzzy Inherently Safer Design Assessment. Inputs and outputs of the FISDI range from 0 to 100 and are categorized in 5 triangular membership functions. The proposed FISDI is applied for the acetic acid production unit. The unit is divided into 7 zones, the four principles based checklist is provided for each zone, and the FISDI is computed for each zone, then the total FISDI is computed for the unit. The results show that the minimum, maximum and total FISDI equal to 29, 72 and 45.1 correspondingly. The whole plant FISDI data is compared to the classic ISDI. The cross-validation accomplished via CFtool in MatLab presents the mean slope of 0.7181 and mean R²=0.7885 which is a justified curve fitting within the scope of the study philosophy_70% of the ISD. The FISDI mainly underestimates the aggregative ISDI. It is noted that the most conformed and the least conformed zone cross-validations are determined as Zone 4 and Zone 7 respectively.

KEYWORDS: ISD, Fuzzy Inference System, FISDI, Hazard

INTRODUCTION

The concept of elimination of hazards rather than using safety barriers and managing risks first introduced by Kletz in 1978. high-inventory processes can be avoided by increasing the re-principle and conversion rate via a mixing process as well as by properly sizing the piping system [1]. About the expert terminology, it can be stated that diverse expressions were used before 1991, although the meanings had the same roots.

Corresponding author: Hamid Sarkheil

Email: Sarkheil_h@yahoo.co.uk

The philosophy of Inherently Safer Design ISD –as introduced by [2] – is to eliminate or decrease the inherent hazards by the acquisition of four principles (so that, these four principles are major among the main factors of inherent safety) all over the system:

1. Elimination/Substitution: Replacing one material with another of less hazard, e.g., cleaning with water and detergent rather than a flammable solvent
2. Minimization: Reducing the amount of hazardous material present at any one time, e.g., by using smaller batches
3. Moderation: Reducing the strength of an effect, e.g., having a cold liquid instead of a gas at high

pressure, or using the material in a dilute rather than concentrated form

4. Simplifications: Problems Eliminations in the design steps rather than another step with adding additional equipment and maintenance program to deal with them and using complex procedures if they are essential [2].

In 1991 in order to achieve the user-friendly approach, Kletz listed following items in the premise of plant design for safety:

- Avoiding knock-on effects;
- Making incorrect assembly impossible;
- Making status clear;
- Ease of control;
- Software and management procedures [3].

Khan and Amyotte in 2003 introduced two more ISD principles being defined as follows [4]:

1. Error tolerance: Processes and Equipment/s can be designed to be capable of withstanding possible faults or deviations from design step. An elementary example is making piping and joints capable of withstanding the maximum possible pressure if outlets are closed.
2. Limit effects by design: Location or transportation of equipment/s in possible condition by less danger, e.g., gravity will take a leak to a safe place, the use of bunds.

The American Institute of Chemical Engineers (A.I.C.E.) in 1990, published its definition of ISD. It is noted that making a facility inherently safer does not automatically reduce the risk. If such measure involves reducing the chemical or physical hazards of operation, this usually translates into a lower severity of consequences if a loss event occurs. Since the risk is a function of both severity of consequences and likelihood, any changes that increase the likelihood of a loss event more than it reduces its potential severity event would actually increase the overall risk [5-6]. An example of minimization principle given by the Center for Chemical Process Safety (2010) shows that although a continuous reactor is a safer choice compared with batch reactor by reducing the impact of accidents, it relies heavily on controller instrumentation [7]. Thus it should be considered inherently less safer. Luyben and Hendershot (2004) have introduced a sample for minimizing the size of the reactor to make an unstable controlling [8]. A significant deviation in process variables can push the process into unsafe regions of operation and affect the product quality. Thus the requirement for controllers and safety measures of the process will be higher than the original one. Other examples of an ISD conflict including selection between volatile and toxic solvent, and selection of ammonia-based

and chlorofluorocarbon refrigerant [9-11, 6], and also risk-based process plant design [12], and introducing of an index (PSI) to assess inherent safety level during preliminary design stage of Acrylic Acid plant and Natural Gas Liquid (NGL) plant, as more studies are in the ISD field [13]. The corresponding design stages for ISD principles are presented in Table 1.

The implementation of ISD should be done in a hierarchical manner where the first-order inherent safety involves the step to avoid or eliminate the hazard, and when the first order of the inherent safety is not applicable, the second-order inherent safety will be considered. The implementation of the second-order inherent safety consists of two steps: severity reduction and likelihood reduction [14].

Another study has proposed an integrate ISD concept accompanied with hazard review technique to inherent hazards identification at an early stage of inherently safer design of plant [15].

Rasuli and Shariff in 2010 were used in their work a modified theory of inventive problem-solving hazard review method to inherent hazards identification [15].

The fuzzy set theory has been developed by Iranian scientist: Zadeh in 1967 for modeling of nonlinear, uncertain and complex systems [16]. Fuzzy inference process is formulating a mapping from a given input to an output according to fuzzy logic [17]. The process of fuzzy inference can be expressed in four phases: membership functions, inference rules (If-then rules), aggregation, and defuzzification [18-22].

Evaluation and qualitative analyzing of Inherent safety cannot be easy, and this is one of the major difficulties in design a plant [23]. An example of the use of fuzzy logic for the measurement of inherent safety handled in the work of Gentile et al., 2003 [23]. This method introduced an overall index for use in process simulation to generate Inherently Safer Alternatives (I.S.As.) and to evaluate them in a systematic plan. The application to process simulation was expected to be useful for the application of inherent safety to operating plants [23]. The fuzzy logic method is helpful modeling uncertainty and subjectivities implied in the evaluation of individual variables, and it is helpful for combining quantitative data with qualitative information [24].

Table 1. The design stage for ISD principles.

Principle	Design Stage		
	Conceptual Design	Process Flow Diagram Design	Piping & Instrumentations Design
1) Elimination/ Substitution	*	*	-
2) Minimization	*	*	-
3) Moderation	*	*	-
4) Simplification	*	*	-
5) Error tolerance	-	-	*
6) Limit effects	*	*	*
7) Avoiding knock-on effects	*	*	-
8) Making incorrect assembly impossible	-	-	*
9) Making status clear	-	-	*
10) Ease of control	*	*	-
11) Software and management procedures	-	-	*

MATERIALS AND METHODS

Methodology Overview: Figure 1 represents the framework for the methodology invented in the study. As it is demonstrated in the overview, the first stage of FISDI assessment is to review the hazard identification and inherently safer design documents. This enhances assessors' knowledge and prepares the audition team attitudes toward the ISD in the present and the past of the system, hence it is completely undeniable. In the second stage, the specific ISD principle based checklists are edited by the researchers. Although ISD documents can help to extract some aimed data for ISD assessment, they are not complete, and they are not permitted to be copied for the following reasons:

- The ISD documents might be out of date.
- The ISD documents cannot provide the format of data for the fuzzy inference system
- The ISD documents might have missing parts and deficiencies in assessments.
- The ISD documents are not prepared for the aim of assessment.

Appendix 1 presents a typical sample of prepared ISD principle based checklists. The audition team audits the process and accordingly fills the checklist items. It is highlighted that the team must ensure that

the documentation is studied perfectly before the checklists are filled. The third stage of the study is to segregate the case study process into 7 zones based on the main vessels present in the industry. Then the checklists are separately filled by the audition team for each zone. In the next step, the overall process is audited, and the gathered checklists are investigated for probably missing parts, mistakes underestimations. After data preparation, the assessment team must ensure that the prepared data are sufficient and they satisfy the FISDI assessment requirements. For this purpose, the database of fuzzy inference system of FISDI assessment are reviewed and compared with the prepared data to find whether the prepared data are compiled and suitable with the knowledge base and rule base and yield proper results. An important advantage of the naming Yes/No step in the methodology is to optimize the best suitability and relation between the case study features and the features of the history, theory, methodology and fuzzy parts of the study.

The 4 ISD principle columns in FISDI checklists are averaged for each zone and each principle separately and the average value for each principle (as input) is inserted into MATLAB R2013a as following to evaluate the fuzzy inherently safer design index in each zone. Finally, the 7 zones' FISDI are averaged to find the total FISDI in the acetic acid production process.

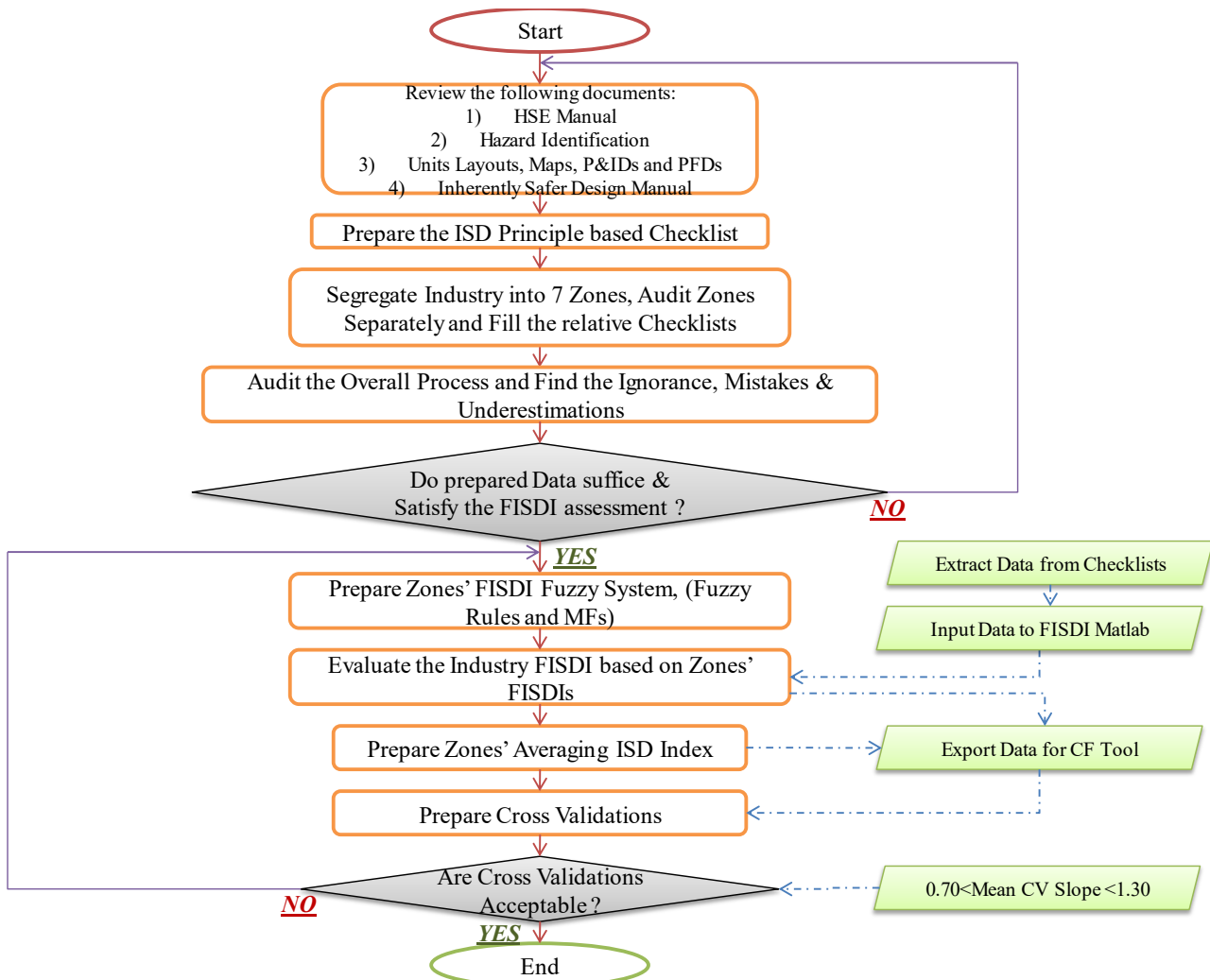

Fig. 1. Overview representation of the study methodologies

Fuzzy Inherently Safer Design Index (FISDI) Assessment

FISDI Fuzzy Inference System: Figure 2 demonstrates the fuzzy inference system for FISDI assessment. The fuzzy inference systems in this study are of kind Mamdani. In accordance, it has four inputs and one output. Each data in FISDI FIS has five triangular membership functions scaled in

x-axis from 0 to 100. The inputs are ISD 4 principles:

- 1) Elimination/Substitution,
- 2) Minimization,
- 3) Moderation and
- 4) Simplification and the output is defined as Fuzzy Inherently Safer Design Index.

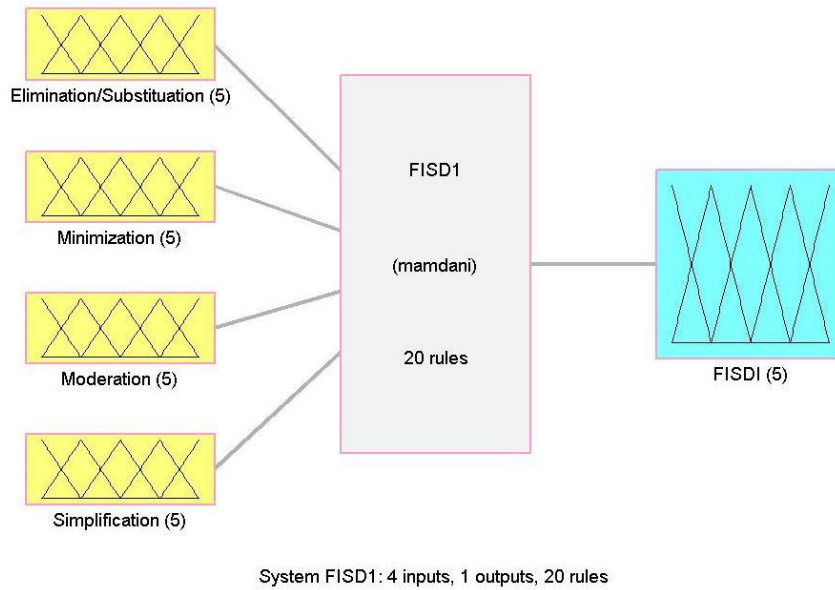

Fig. 2. Overview representation of the FISD Fuzzy Inference System

FISDI Membership Functions: Figure 3 and four respectively show the membership functions for Elimination/Substitution and FISDI and are named as following (with the relative triangular membership function cut points):

- Very Low (0,0,25)
- Low (0,25,50)
- Average (25,50,75)
- High (50,75,100)
- Very High (75,100,100)

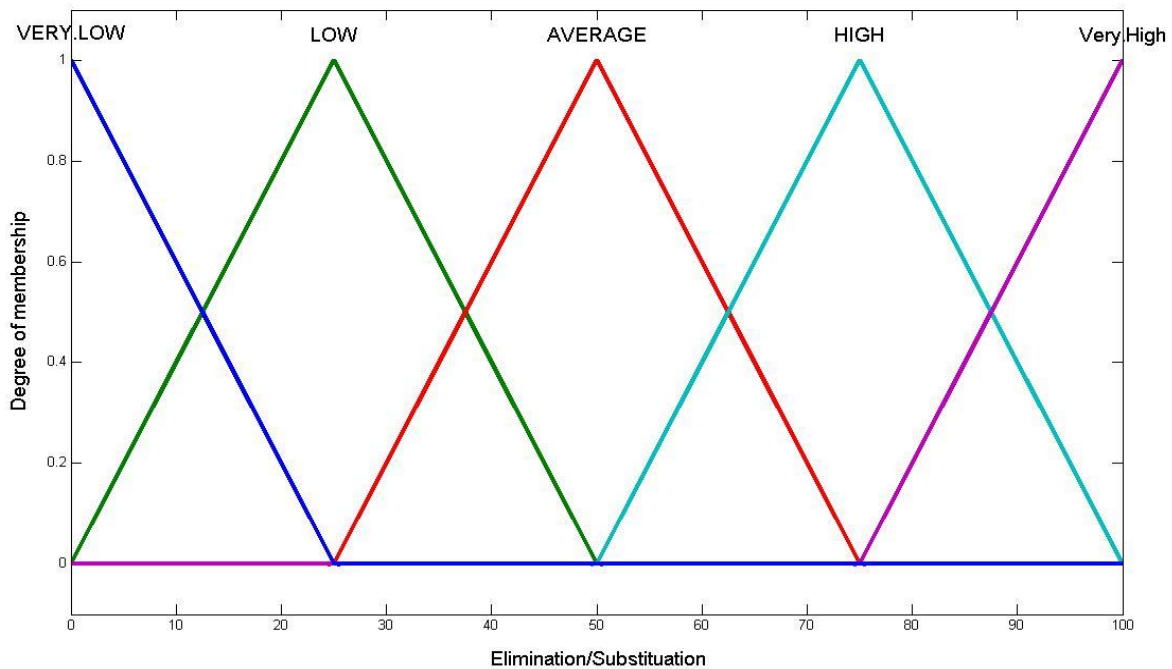

Fig. 3. Elimination/Substitution input data MFs (Membership Functions)

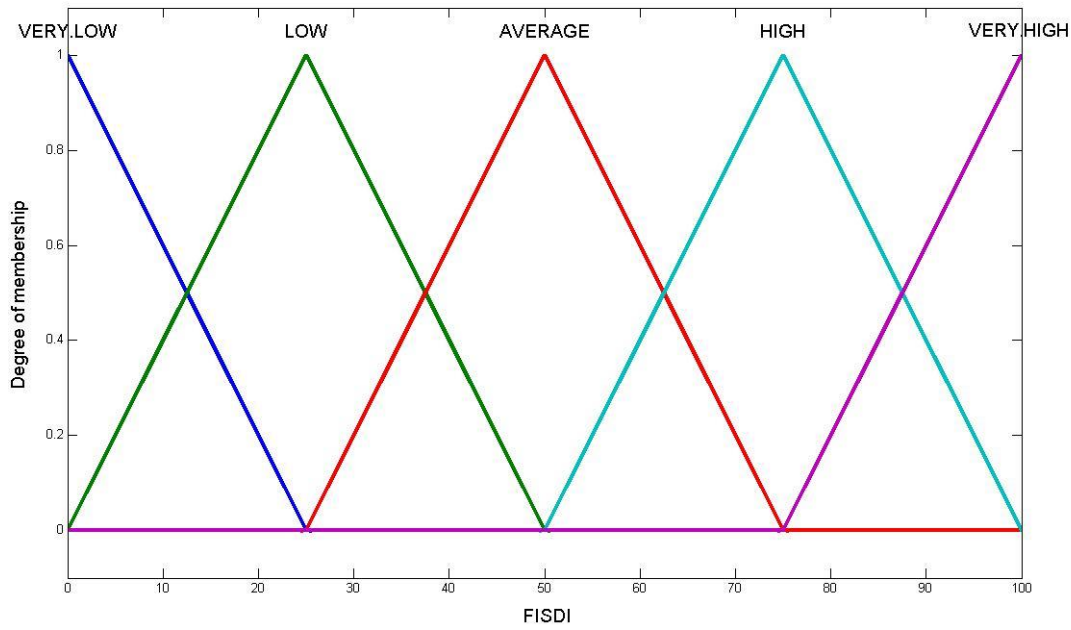

Fig. 4. FISDI Output data MFs (Membership Functions)

FISDI Fuzzy Rules: The number of fuzzy rules in rule base of the FISDI FIS is 20. Table 2

presents the FISDI rules in a verbose format.

Table 2. FISDI Fuzzy Rules Model (Verbose Format)

Inputs:	Elimination/Substitution	Minimization	Moderation	Simplification
Output:	Fuzzy Inherently Safer Design Index FISDI			
Rule 1	If Input is Very Low, then the Output is Very Low (Weight=1)			
Rule 2	If Input is Low, then the Output is Low (Weight=1)			
Rule 3	If Input is Average, then the Output is Average (Weight=1)			
Rule 4	If Input is High, then the Output is High (Weight=1)			
Rule 5	If Input is Very High, then the Output is Very High (Weight=1)			
Example1	If Minimization is Low, then the FISDI is Low (Weight=1)			
Example2	If Simplification is Very High, then the FISDI is Very High (Weight=1)			
Example3	If Elimination/Substitution is Average, then the FISDI is Average (Weight=1)			
Total Rules	Rule1 to Rule5 is repeated for all four input data.			Total Number of Rules=20

FISDI Fuzzy Evaluations: Fig.5 illustrates the fuzzy rule view for the FISDI fuzzy evaluations. It is noted that the defuzzification method in this FIS is in kind of Center of Gravity (COG) obeying the following formula.

$$Z_{COG} = \frac{\int \mu_A(z)zdz}{\int \mu_A(z)dz}$$

On the other hand, AND method, OR method, Implication method and Aggregation method are respectively set as Min, Max, Min, and Max.

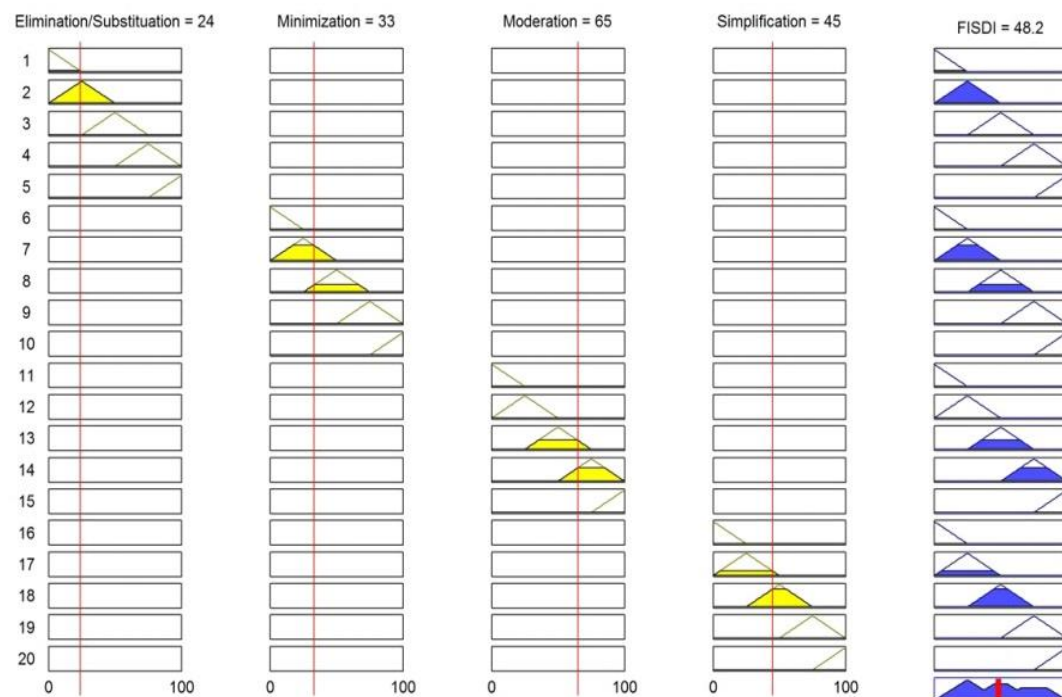

Fig. 5. FISDI Rule View (Fuzzy Evaluations)

CASE STUDY

Acetic Acid Production Plant: Figure 6 is demonstrated the chemical process of acetic acid production via principle between methanol in the liquid phase and carbon monoxide in the presence of radium iodocarbonile as a catalyst. Through the process, methanol is carboxylized and refined acetic acid is produced. The naming carboxylation principle is performed through the carboxylizor reactor (Vessel 1) at a temperature of 170 oC and pressure of 30 bar. The exhaust gas from Vessel 1 arrives at separator (Vessel 2) where CO and inert separate from heavy components. Then the light components are delivered to a scrubber (Vessel 3) so that the organic compounds can separate using methanol. The heavy parts of the separator (Vessel 2) and the outlet methanol from scrubber (Vessel 3)

return to the reactor (Vessel 1) for recovery. The outlet liquid from the reactor (Vessel 1) goes to distillation tower (Vessel 4) of which both top and bottom parts return to the reactor (Vessel 1) for recovery. The middle distillate: acetic acid from (vessel 4) is sent to drier (Vessel 5) for the elimination of humidity. The dried acetic acid goes to production tower (Vessel 6) so that the heavy byproducts can leave the vessel. Finally, the exit acetic acid from (Vessel 6) goes to (Vessel 7) for more purification.

It is noteworthy that the present chemicals have diverse degrees of toxicity and inflammability and the process streams have diverse rates all of which need precise ISD audition. The nominal capacity of this process is about 100,000T/annum.

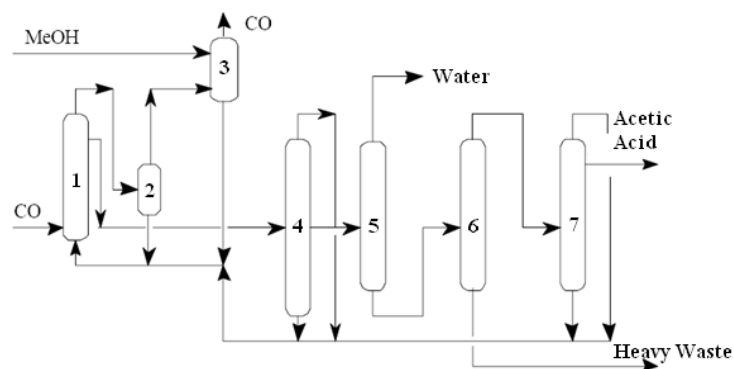

Fig. 6. Case Study Overall Process Flow Diagram (PFD)

Case Study FISDI Checklists: As explained in part 2.1., The prepared format of FISDI checklists are filled by the audition team – comprising 1 HSE Leader, 1 Secretary, 4 HSE Experts and 4 Safety and Risk Officers-for each numbered Vessel (7 Zone) separately. The auditions are accomplished via several sessions of both

visiting the site and meetings for reviewing the documents. Table 3 presents the final version of FISDI checklist filled by audition team for reactor Vessel 1 (Zone 1).

Table 3. Final version of FISDI checklist for reactor Vessel 1 (Zone 1)

Date		Head Auditor: Supervisor:		Audited Organization	
Zone NO: 1	Zone Main Vessel: Reactor	Zone Main Vessel Nominal Capacity:100MT/year	Zone Nominal Power: 1000W/g	Zone ISD Documentation Checked? Yes	Zone Plans & Diagrams Prepared & Checked*? Yes
<i>ISD Elements:</i>		<i>ISD Four Principles (% Implementation):</i>			
		1)Elimination /Substitution	2)Minimization	3)Moderation	4)Simplification
<u>Piping & Instrumentation:</u>					
	Piping Material	15	10	0	0
	Piping Dimensions	15	15	0	0
	Piping Layout	30	0	0	65
	Instrumentation Conditions	70	35	0	5
	Instrumentation and Control System Relation	55	40	5	10
<u>Energy & Material:</u>					
	Energy Rates	40	35	10	0
	Energy Sources	20	30	5	0
	Material Rates	25	60	5	0
	Material Sources	50	25	35	0
	Toxicity	70	15	0	0
	Flammability	40	35	10	0
	Explosion	40	30	20	5
<u>Site Layouts</u>					
	Vessel Layouts	85	40	40	90
	Equipments Layouts	95	60	50	100
	Ways Layout	95	50	40	100
	House Keeping Requirements	85	35	65	80
<u>Site Conditions</u>					
	Hot Surfaces	85	100	50	0
	Sharp Edges	95	100	50	0
	Height	60	95	0	75
	Depth & Excavations	85	60	0	0
	Electricity	85	100	0	15
	Thunders	95	5	0	0
	Conceptual Design	90	70	0	100
<u>Control System</u>					
	PLC, DCS,... Automation	55	35	30	85
	System Fails	65	35	20	45
	Human Errors	45	15	10	55
	System Communications	35	20	5	25
Average		60	42	16	31

RESULTS AND DISCUSSION

Case Study FISDI: The average values for 4 ISD principles of each 7 zone are inserted into the

FISDI FIS as input elements (scaled between 0 and 100). Table 4 presents input data of FISDIs for 7 zones along with their corresponding assessed FISDI outputs. According to the data, Figure 7 illustrates the quite uniform distribution for an average of 4 ISD principles in the case study.

Table 4. FISDI Inputs and Outputs for a case study

Zone	Inputs (4 ISD Principles)				Outputs FISDI
	1)Elimination /Substitution	2)Minimization	3)Moderation	4)Simplification	
Zone 1	60.00	42.00	16.00	31.00	45.10
Zone 2	22.00	31.00	28.00	13.00	29.20
Zone 3	70.00	62.00	56.00	67.00	62.60
Zone 4	23.00	32.00	21.00	31.00	32.10
Zone 5	62.20	52.20	48.70	69.40	59.90
Zone 6	24.00	33.00	45.00	65.00	48.30
Zone 7	76.00	69.00	87.00	91.00	72.10
Total					49.10
Average	45.74	46.08	49.23	46.64	45.10

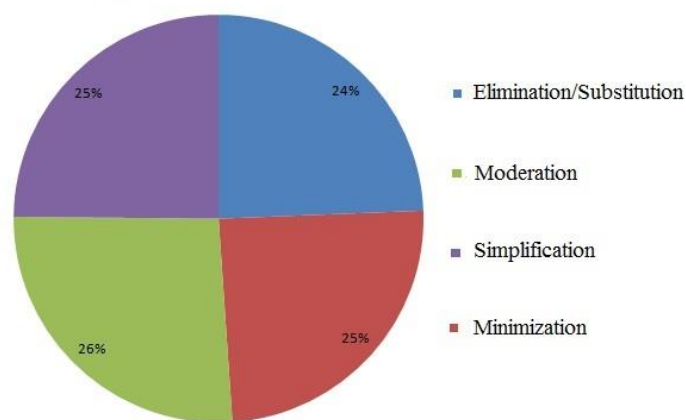
Average 4 ISD Actions Pie Chart**Fig.7.** Pie chart for an average of 4 ISD Principles relationship in Case Study

About an average of the ISD principles, it could be recognized that they all fall into same membership function: average. So that shows the safety management system has allocated time, cost and resources in the field of inherently safer design in the best-justified manner in which the 4 ISD principles are invested equally. So that means the safety management system believes in every 4 ISD principles and this has influenced their design to exhibit every four principles equally. However, the membership function is average which is away from the ideal ISD. Higher levels of ISD would be found by having greater average values for 4 ISD principles. Although the compromise between reduction of hazards inherently by ISD and control of risks in further steps by HSE-MS is the responsible factor for the quality and quantity of ISD principles and eventually the FISDI and it is directly related to decisions made by the industry safety management system and HSE committee. Figure 8 presents the results of FISDI fuzzy inference system including the engagement of 4 ISD principles for 7 zones and the case study.

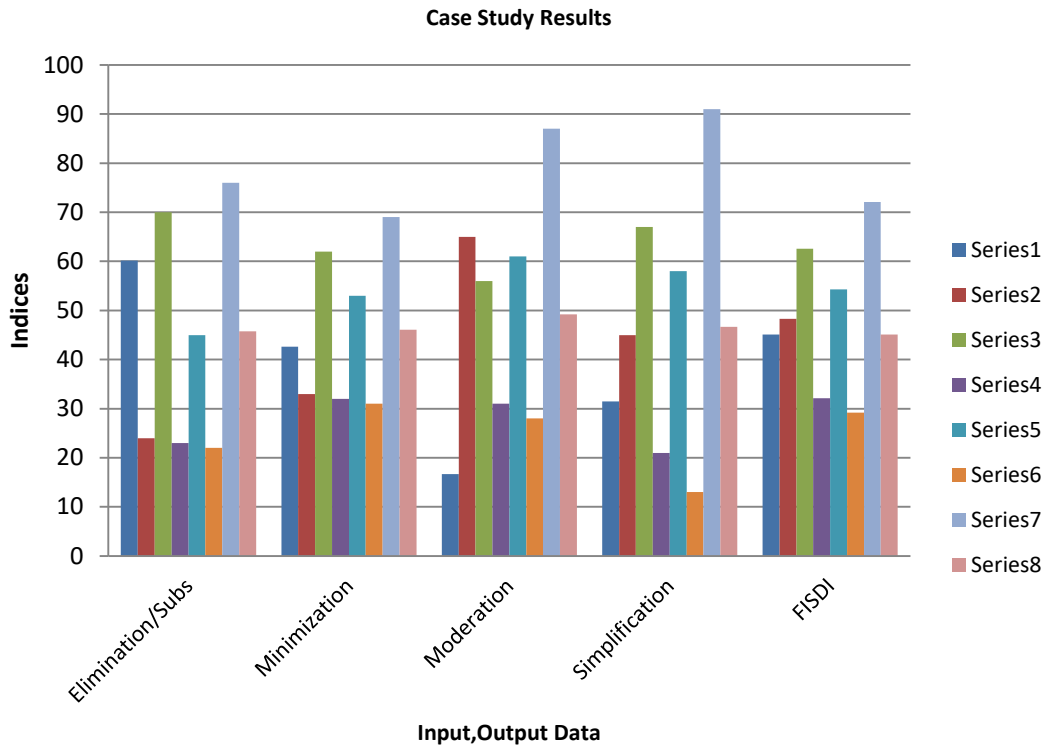

Fig. 8. Comparison bars for Case Study Results

It is found that maximum and minimum values for FISDI belong to zone 7 being equal to 72.1 (High membership function) and zone 2 is equal to 29.2 (Low membership function) respectively. On the other hand, the overall case study FISDI equals 45.1 (average membership function) which is very close to the average of 7 zones FISDI's being equal to 49.1 (average membership function). So that shows the industrial safety management system approach toward ISD principles and respectively the FISDI's has the minimum variations and discriminations from one zone to another. Hence the ISD and FISDI rarely

deflect from the principles in any part of the plant. It can result that the safety management system attitude toward ISD is integration and equity of ISD 4 principles in every part of the plant such that the FISDI's are often preserved in average membership function just as illustrated in Figure 9. Figure 9 presents the percentages of engaged membership functions of FISDI's for each zone. It is clear that all 7 zones are engaged within average membership function among which zones 1, 3, 5 and 6 have major average membership function, and zones 2, 4 and 7 have minor average membership function.

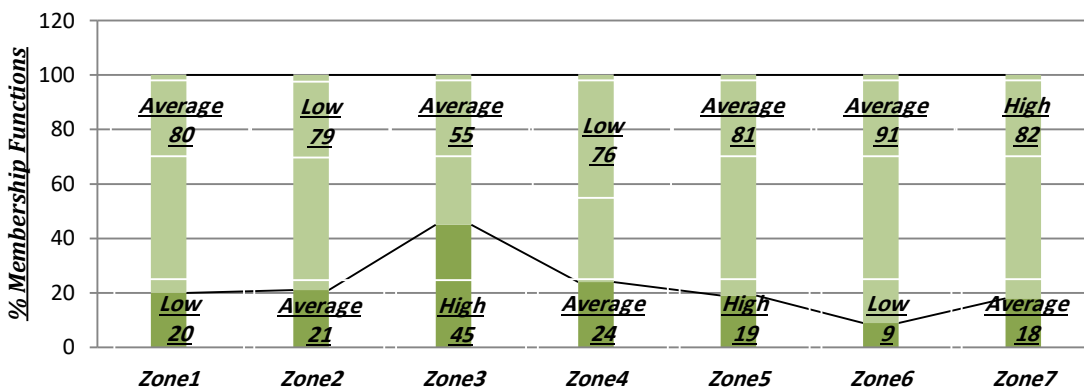

Fig. 9. Comparison bars for membership function percent's of FISDI's in zones

FISDI Vs. ISDI Cross Validations: In this step, it is tried to develop sophisticated comparisons between the FISDI in methodology and classic ISD index derived from averaging attitude by the below equation.

$$ISDI = 1/4 \sum_{i=1}^4 (\% \text{Implementation of } i^{\text{th}} \text{ Principle}) ;$$

The relative scales of the ISDI levels and the corresponding Definitions are prepared in Table 5.

Table 5. Allocation of classic ISDI levels and definitions





Levels	Ranges	Color	Definitions
Very High ISD	[80, 100]		ISD is completely achieved
High ISD	[60, 80]		ISD is achieved although some deviations are found
Moderate ISD	[40, 60]		Achievement of ISD is SO SO, Not High and Not Low ISD
Low ISD	[20, 40]		Achievement of ISD is defective
Very Low ISD	[0, 20]		ISD is not achieved, ISD is absent

Table 6 presents analyses of FISDI and ISDI comparison for Zone 4 as the best fit among cross-validation of Zones. The cross-validation data for Zone 4 are illustrated as Figure 10. The Slope of the Regression Line (S.R.L.) is 1.027 with R square

of 0.8582. In contrast, the data for cross-validation of Zone 7 is illustrated in Table 7, and Figure 11 which is determined as the least conformed fit among the Zones.

Table 6. PTW process stages for effectiveness assessment

ISD Elements:	ISD Four Principles (% Implementation):				Outputs	
	1)Elimination /Substitution	2)Minimization	3)Moderation	4)Simplification	ISDI	FISDI
Piping & Instrumentation:	38	48.0	19.0	15.00	30	36.2
Energy & Material:	20	34.0	12.0	20.00	22	31.5
Site Layouts:	27	26.0	23.0	33.00	27	33.5
Site Conditions:	20	21.0	28.0	32.00	25	32.6
Control System:	10	37.5	27.5	63.75	34	44.1
Total Zone:	23	32.0	21.0	31.00	27	32.1

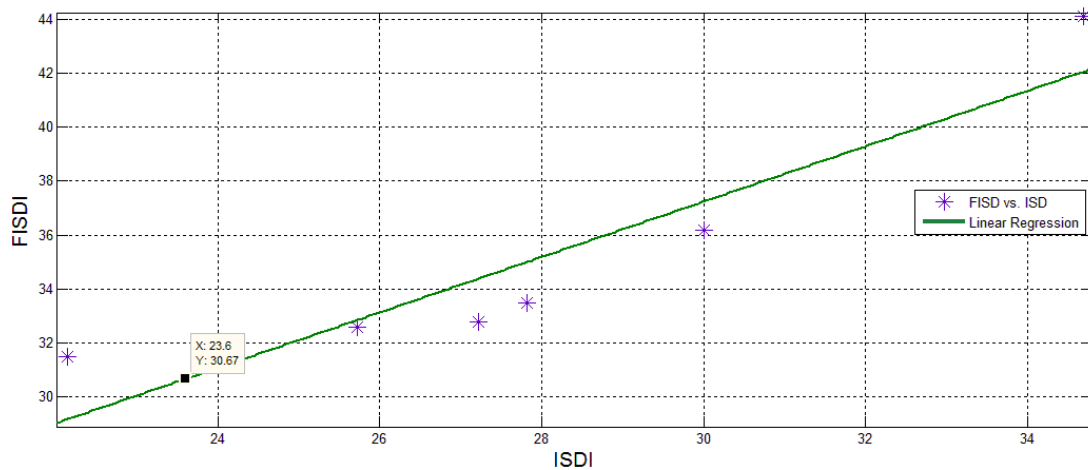

Fig.10. Cross-Validation of FISDI Vs. ISDI for Zone 4

Table 7. Analyses of FISDI & ISDI comparison for Zone 7

ISD Elements:	ISD Four Principles (% Implementation):				Outputs	
	1)Elimination /Substitution	2)Minimization	3)Moderation	4)Simplification	ISDI	FISDI
Piping & Instrumentation:	79	64.00	75	98	79.00	70.0
Energy & Material:	73	72.00	94	90	82.86	76.4
Site Layouts:	73	71.00	87	98	82.81	75.2
Site Conditions:	71	69.00	86	79	76.00	70.9
Control System:	88	68.75	90	97	86.25	72.9
Total Zone:	76	69.00	87	91	81.07	72.6

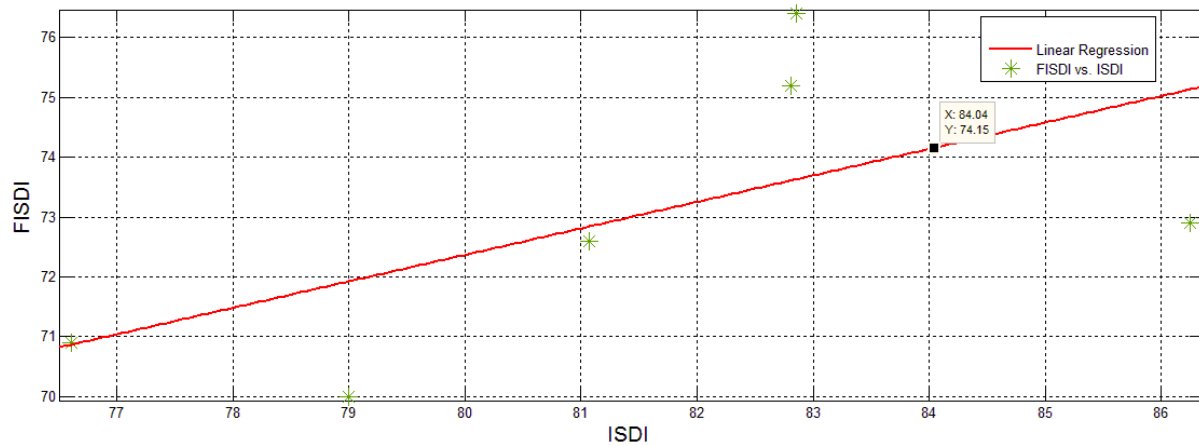

Fig. 11. Cross-Validation of FISDI Vs. ISDI for Zone 7

The results of surveys and interviews with 14 experts using structured Delphi method in two rounds (Fig. 2) indicated that questions raised in the checklist are system identification (Table 5).

In this study, first applications of the Delphi method after preparation of structure, top related experts selected and primary common questions

released. In first round, responses to questions were evaluated. In the second round to select more appropriate questions, and released have been set. In addition, the objective of the method was to combine expert opinions on likelihood and expected development time, of the particular technology, in a single indicator.

Table 8. Analyses of FISDI & ISDI comparison in the case study

Zone	Fit Function	Confidence Bounds	Goodness of Fit		
			SSE	R ²	RMSE
1	Y=0.5905X+19.73	95%	15.93	0.9751	1.996
2	Y=1.116+2.608	95%	6.732	0.8938	1.297
3	Y=0.6582X+17.56	95%	46.93	0.785	3.425
4	Y=1.027X+6.426	95%	15.5	0.8582	1.968
5	Y=0.7714X+10.18	95%	56.03	0.7332	3.743
6	Y=0.5354X+23.27	95%	20.4	0.8587	2.259
7	Y=0.4422X+36.99	95%	18.94	0.3684	2.176
Total	Y=0.6042X+19.6	95%	7.58	0.8362	1.377
Mean	Y=0.7181X+14.72	Mean Cross Validation		Mean CV slope: 0.7181>0.70	

It can be understood from Table 8 that the Fuzzy ISD Index underestimates the classic ISD Index and this relates to the methodological attributes of the fuzzified reasoning. The mean cross-validation slope for the evolving FISDI equals 0.7181 – within 70% level - which is a justified curve fitting as it is predefined in Figure 1. Finally, it can be inferred that the fuzzy ISD assessment and the classic ISDI have close relationships with each other, although the fuzzy inference is more hybrid, more precise and more flexible and it brings into account the intersections of levels; as well, it resolves the problems are engaging uncertainties.

CONCLUSION

In this study, the inherently safer design assessment for an Acetic Acid Production Unit is accomplished via the development of fuzzy inference systems studying 4 ISD principles proposed by Kletz [3]. Although the ISD philosophy itself is a methodology to achieve fundamentally safer plants, conflicts between principles can deviate from their original intention [6].

However, in this study the corresponding industrial safety management system could overcome the problems related to the conflicts between principles by imposing equilibrium and integration between the naming 4 ISD principles sophisticatedly. As the results express, the integration and justness between principles (having same membership functions and close parts) can be found in every zone of the process. And also this brings about close FISDI for all zones, and this is while the values for FISDI are kept around average, and the remaining hazards should be dealt with in further steps as risk assessment and risk management studies. Indeed, the integration of ISD and HSE-MS for achieving perfect safety is still vital, and it is an inevitable truth. The predominant factor for preference of ISD rather than process safety management PSM –which is a related subject– can be served as the managerial factor affecting the management system decision makings. Subjects like: Cost-Benefit Analysis CBA, ISD assessment, HSE culture, and Sustainable Development are the most important parameters influencing decision making of industrial management system and respectively the

industrial safety management system about ISD preferences. The management system can make more explicit decisions about ISD and HSE-MS by the development of the scientific study of Fuzzy ISD Index Assessment just as assessment is the base of any management.

Statistical considerations, various uncertainties, non-linearity of functions, conflicts between the 4 ISD principles and complexity of relations in the subject of ISD implementation and its assessment are the most important reasons for the utilization of fuzzy inference in this research.

An extension of this study, the researchers suggest the utilization of further ISD principles in fuzzy systems to bring their impact into ISD assessments and to have more comprehensive decision makings.

ACKNOWLEDGEMENTS

The authors would like to thank College of Environment for its support throughout the study. In addition, the authors declare that there is no conflict of interest.

Appendix 1

Appendix 1. Atypical format of ISD principle based checklist for FISDI assessment

Date:		Head Auditor:			Audited Organization	
		Supervisor:				
Zone NO:	Zone Main Vessel:	Zone Main Vessel Nominal Capacity:	Zone Nominal Power:	Zone ISD Documentation Checked?	Zone Plans & Diagrams Prepared & Checked*?	
ISD Elements:		ISD Four Principles (% Implementation):				
		1)Elimination /Substitution	2)Minimization	3)Moderation	4)Simplification	
<u>Piping & Instrumentation:</u>						
Piping Material						
Piping Dimensions						
Piping Layout						
Instrumentation Conditions						
Instrumentation and Control						
System Relation						
<u>Energy & Material:</u>						
Energy Rates						
Energy Sources						
Material Rates						
Material Sources						
Toxicity						
Flammability						
Explosion						
<u>Site Layouts</u>						
Vessel Layouts						
Equipments Layouts						
Ways Layout						
House Keeping Requirements						
<u>Site Conditions</u>						
Hot Surfaces						
Sharp Edges						
Height						
Depth & Excavations						
Electricity						
Thunders						
Conceptual Design						
<u>Control System</u>						
PLC, DCS,... Automation						
System Fails						
Human Errors						
System Communications						
* Isometric Plans, PFDs: Process Flow Diagrams, P&IDs: Piping & Instrumentation Diagrams, UTMs and the Maps for Platforms, Pavements, access Ways and Roads.						

REFERENCES

- Kletz TA. Learning from Accidents, 3rd ed. Butterworth-Heinemann, Oxford. pp. 129, 2001.
- Kletz TA. What You Do not Have, Can't Leak', Chemistry and Industry, pp. 287–292, 1978.
- Kletz TA. Plant Design for Safety – A User-Friendly Approach, Hemisphere, New York. 1991.
- Khan FI, Amyotte PR. How to make inherent safety practice a reality. *Can J Chem Eng.* 2003;81: 2–16. <http://dx.doi.org/10.1002/cjce.5450810101>.
- Center for Chemical Process Safety. Guidelines for Hazard Evaluation Procedures, 3rd ed. John Wiley & Sons, New York. 2011.
- Abidin MZ, Rusli R, Azmi MS, Khan FI. Three-Stage ISD Matrix (TIM) Tool to Review the Impact of Inherently Safer Design Implementation, *Process Saf Environ* 2016; 99:30–42. <http://dx.doi.org/10.1016/j.psep.2015.10.006>.
- Center for Chemical Process Safety. Inherently Safer Chemical Processes: A Life Cycle Approach. Wiley, New York. 2010.
- Luyben WL, Hendershot DC. Dynamic disadvantages of intensification in inherently safer process design. *Ind Eng Chem Res* 2004;43:384–396. <http://dx.doi.org/10.1021/ie030266p>.
- Hendershot DC. Inherently safer design: an overview of key elements. *Prof Saf*, 2011; 48–54.
- Hendershot DC. An overview of the inherently safer design. *Process Saf Prog.* 2006; 25:98–107. <http://dx.doi.org/10.1002/prs.10121>.
- Hendershot DC. Conflicts and decisions in the search for inherently safer process options. *Process Saf Prog.* 1995;14:52–56. <http://dx.doi.org/10.1002/prs.680140109>.
- Rathnayaka S, Khan F, Amyotte P. Risk-based process plant design considering inherent safety, *Safety Sci* 2014; 70:438-464.
- Shariff A M, Leong C T, Zaini D. Using the process stream index (PSI) to assess inherent safety level during the preliminary design stage, *Safety Sci* 2012;50:1098-1103.
- Moore D A, Hazzan M, Rose M, Heller D, Hendershot DC, Dowell AM. Advances in inherent safety guidance. *Process Saf Prog* 2008; 27:115–120.
- Rusli R, Shariff AM, Qualitative Assessment for Inherently Safer Design (QAISD) at the preliminary design stage. *J Loss Prev Process Ind* 2010; 23:157–165.
- Ross T. Fuzzy Logic with Engineering Applications. John Wiley & Sons. 2004.
- Mo-Yuen C. Methodologies of Using Neural Network and Fuzzy Logic Technologies for Motor Incipient Fault Detection. World Scientific, Singapore. 1997.
- Zadeh LA. Fuzzy sets as a basis for the theory of possibility. *Fuzzy Sets Syst* 1978;1:3-28.
- Ocampo W, Ferré N, Domingo J, Schuhmacher M. Assessing water quality in rivers with fuzzy inference systems: a case study. *Environ Int* 2006;32:733-742.
- Soler V. Lógica difusa aplicada a conjuntos imbalanceados: aplicación a la detección del síndrome de Down. Ph.D. thesis. Departament de Microelectrònica i Sistemes Electrònics, Universitat Autònoma de Barcelona. 2007.
- Sarkheil H, Rahbari S. Development of case historical logical air quality indices via fuzzy mathematics (Mamdani and Takagi–Sugeno systems), a case study for Shahre Rey Town. *Environ Earth Sci* 2016; 75:1319. doi:10.1007/s12665-016-6131-2.
- SHAMAI A, OMIDVARI M, HOSSEINZADEH LOTFI F. HSE Unit Performance Assessment Model in the Steel Making Industry Using Fuzzy Systems. *ijoh.* 8(2):100-9.
- Gentile M, Rogers WJ, Mannan MS. Development of a Fuzzy Logic-Based Inherent Safety Index. *Process Saf Environ.* 2003;81(6):444-456. <http://dx.doi.org/10.1205/095758203770866610>
- Wang Q, Wang H, Qi Z. An application of nonlinear fuzzy analytic hierarchy process in safety evaluation of coal mine, *Safety Sci* 2016;86:78-87.